

Experiment 1

DC Instruments and Measurements

1 Motivation

This experiment introduces you to some of the laboratory instruments that you will use throughout the semester. Today's experiment focuses on DC measurements of voltage and current. Ideal measurement instruments do not perturb a circuit, but real instruments always have some finite impact. You will observe how real voltmeters and ammeters can sometimes have non-negligible effects that cannot be ignored.

A prelab assignment is included in this writeup, see below. Prelab assignments will typically be given in separate documents in future labs. The prelab assignment should always be completed *before* coming to the lab!

2 Background

A fundamental circuit configuration is the **voltage divider**. Voltage dividers are formed using **resistor networks**. As the name suggests, a “divider” outputs a fraction of an input voltage. The specific fraction is determined by the values of the resistors in the network according to two basic rules that apply to all electrical circuits:

- The voltage across **parallel branches** of a circuit must be the same
- The current through **components in series** must be the same

Resistors are electronic components that can be manufactured to obey **Ohm's Law** very precisely

$$V = IR \tag{1}$$

where R represents the value of the resistance (units of ohms, Ω), V is the voltage across a resistor, and I is the current flowing in the resistor.

A **voltmeter** is a device that measures a difference in electric potential (voltage). The voltmeter is attached across two points in a circuit and registers the potential difference (voltage) between these two points. Ideally, no current flows through the voltmeter (i.e., it has infinite resistance) so it has no effect on the circuit when it is attached. Therefore the voltmeter itself is not usually included on the circuit diagram, although the points where it is attached can be labeled to identify the particular voltage difference that is being measured.

3 Equipment

For this lab, you will need:

- One DC power supply with white chassis
- Two DMM4020 digital multimeters
- One “old-fashioned” Simpson VOM
- Two ELC variable resistance boxes
- One incandescent light bulb

4 Procedure

4.1 Measuring Voltage with Real Devices

Build the circuit shown in Fig. 1 using the small white DC power supply (green and black output terminals) and two ELC variable resistance boxes. Do not attach any voltmeters yet.

1. Adjust the output voltage, V_0 , of the power supply to be about $V_0 = 5\text{ V}$.
2. Set one of the DMM4020 digital multimeters to DC V. Using the “INPUT HI” and “LO” jacks, measure V_{12} , V_{23} , and V_{13} for $R_1 = R_2 = 20\text{ k}\Omega$. **Use only one voltmeter and measure each voltage independently.**
3. Repeat these measurements using the Simpson meter set to the 10 V scale.
4. Change the resistors to $R_1 = R_2 = 2\text{ M}\Omega$ and repeat Steps 2 and 3 for both meters.
5. Now set $V_0 = 3\text{ V}$ and repeat the voltage measurements only for the $2\text{ M}\Omega$ resistors using only the DMM4020 digital multimeter.

If the voltmeter was **ideal** (i.e., it “draws” no current, as if it has infinite resistance), then we would expect $V_{12} + V_{23} = V_{13}$, independent of the values of R_1 and R_2 . Create a table in your lab notebook that summarizes your measurements, including the percentage differences between $V_{12} + V_{23}$ and V_{13} . (So 7 columns and 5 rows: R_1 , R_2 , meter used, V_{12} , V_{23} , V_{13} , and % difference) Can you explain these results? Write a brief explanation below your table of measurements.

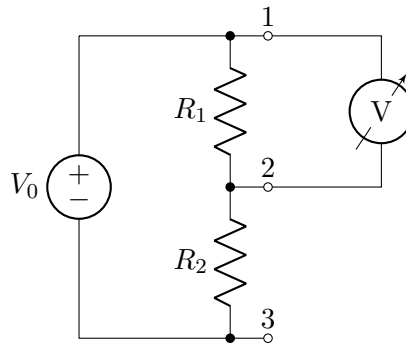

Figure 1: Basic voltage divider circuit. The voltmeter is shown in position to measure the electric potential between nodes 1 and 2.

Prelab Assignment – Experiment 1

Look up the “input impedance” of the DMM — this is its effective resistance. This information can generally be found in the manual for electronic instrumentation. The manuals for the instruments used in this course are in the Files folder in the PHY 321 course on Canvas. The impedance number you are looking for should come under the heading “Specifications”, and it’s usually quicker to look this up in the table of contents than to page randomly through a 200-page manual.

The input impedance often depends on what scale you are on. For the Simpson meter, these old non-electronic meters usually specified the “sensitivity” in ohms/volt rather than the input impedance. You multiply this by the full-scale voltage of the range you are using to get the input impedance. For the Simpson meter, the sensitivity is 20,000 ohms/volt, so when set to a 10 V scale, it will have an input impedance of 200 kohms.

Make three copies of the circuit showing a resistor representing the meter in each of the three measurement positions. Calculate the voltage across this resistor, which will be the voltage indicated on the meter, for each position. Do this for each of the five cases in the instructions, and generate the table described above. Note that when you repeat the measurement with the lower V_0 , the digital multimeter will automatically switch to the lowest range that includes the measured voltage.

Note that since your numbers here are calculated, they will not have any uncertainty. But when you do the lab, you should estimate the uncertainties in these numbers as explained by your TA.

4.2 Resistor Linearity

In the previous section you investigated the non-ideal behavior of two voltmeters. But how do you know if the resistors behave ideally? You have been assuming that Ohm's Law is always obeyed. Is this really true?

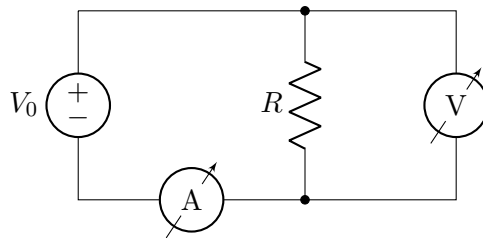

Figure 2: Circuit to measure I and V for a resistor

1. Build a circuit to measure the voltage across and current through an $R = 40\ \Omega$ resistor as shown in Fig. 2. Use the digital multimeter to measure the voltage. For the current meter, use the second digital multimeter set to DC I. You will need to use the input jacks labeled "10 A" (+) and "INPUT LO" (-).
2. Measure the current for voltages ranging from -2 V to $+4\text{ V}$ in 1 V increment.
3. Make a plot of I vs V in your lab notebook. Note that when plotting measured data points, you should never just 'connect the dots' with lines, rather use symbols ("+", "•", "×", etc.) for each measurement point. You can, however, use a continuous line as a plausible model for the data. In this case, use a ruler and draw the best-fit straight line on the graph. It is probably quickest to just make a plot by hand in your notebook, but feel free to use a spreadsheet using the lab's computers. Learning to use spreadsheets for making plots and fitting data will be useful in the coming labs.
4. Does the resistor obey Ohm's Law (i.e., is it "linear")?
5. Now redo your experiment using an incandescent light bulb in place of the resistor. Take points at the same voltages and plot them on the same graph.
6. The brightness of the filament is an indication of its temperature. What happens to the temperature and resistance as the voltage increases? Does the filament obey Ohm's Law?